

ALTERNATIVE 1 - INITIAL SETTING

HIGHER ROLL CENTER ADJUSTMENT

Higher roll center adjustment increases on-power steering and better rotation of the car. However, it decreases rear traction and therefore this setting is recommend for medium and high-traction conditions.

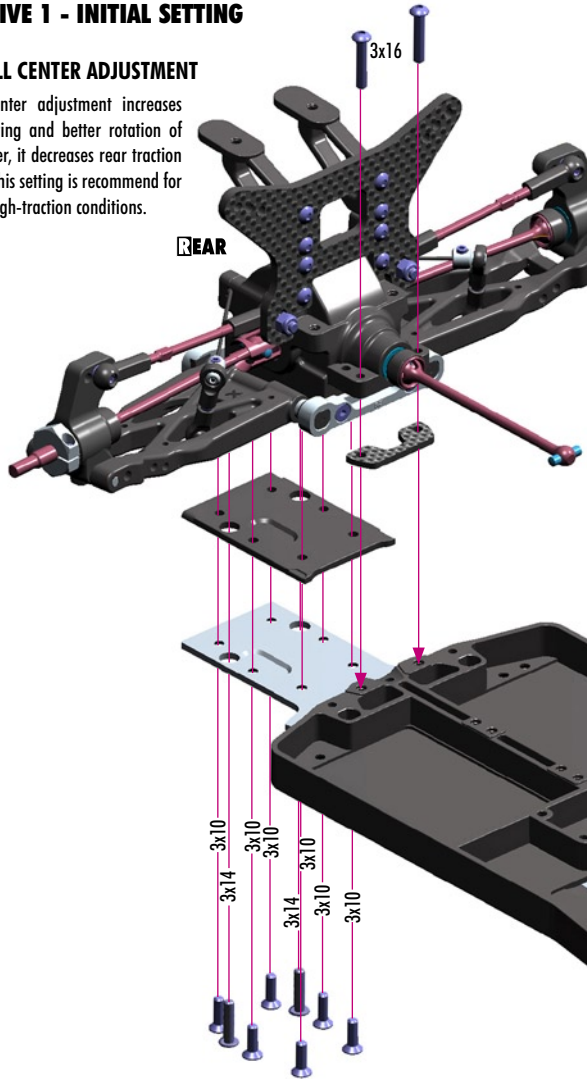

ALTERNATIVE 2 - OPTION

LOWER ROLL CENTER ADJUSTMENT

Lower roll center adjustment generates more rear traction and makes the car easier to drive but generates more on-power push. Recommend for low and medium-traction conditions.

Optional suspension holders must be used:

#363311
Alu Rear Lower Suspension Holder
+ 2 - Front

#363321
Alu Rear Lower Suspension Holder
+ 2 - Rear

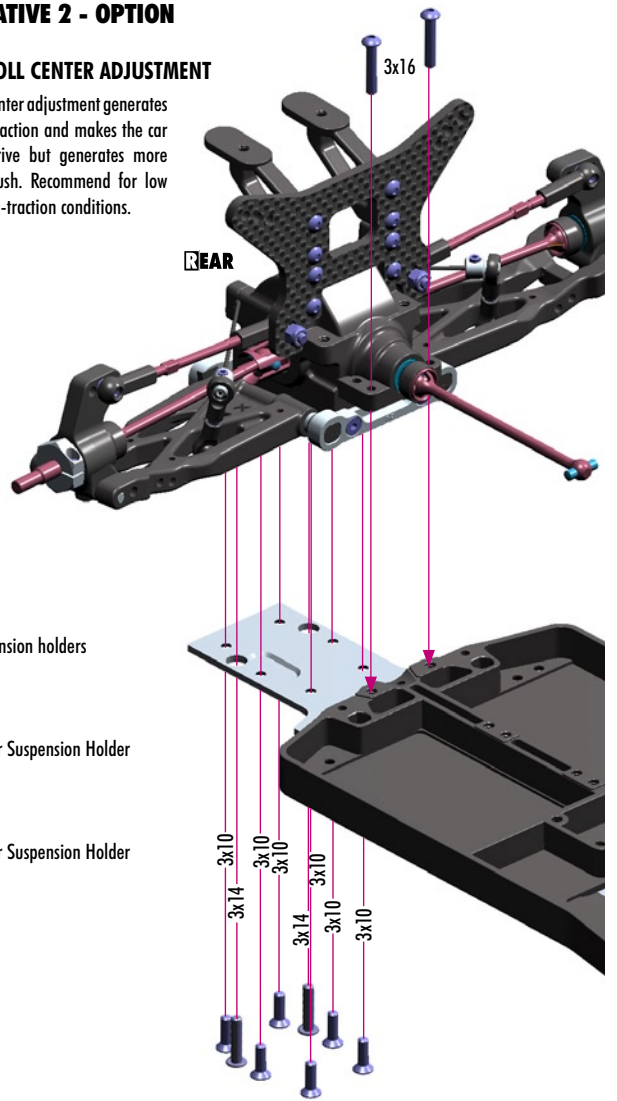

970120
O 12x1

4x

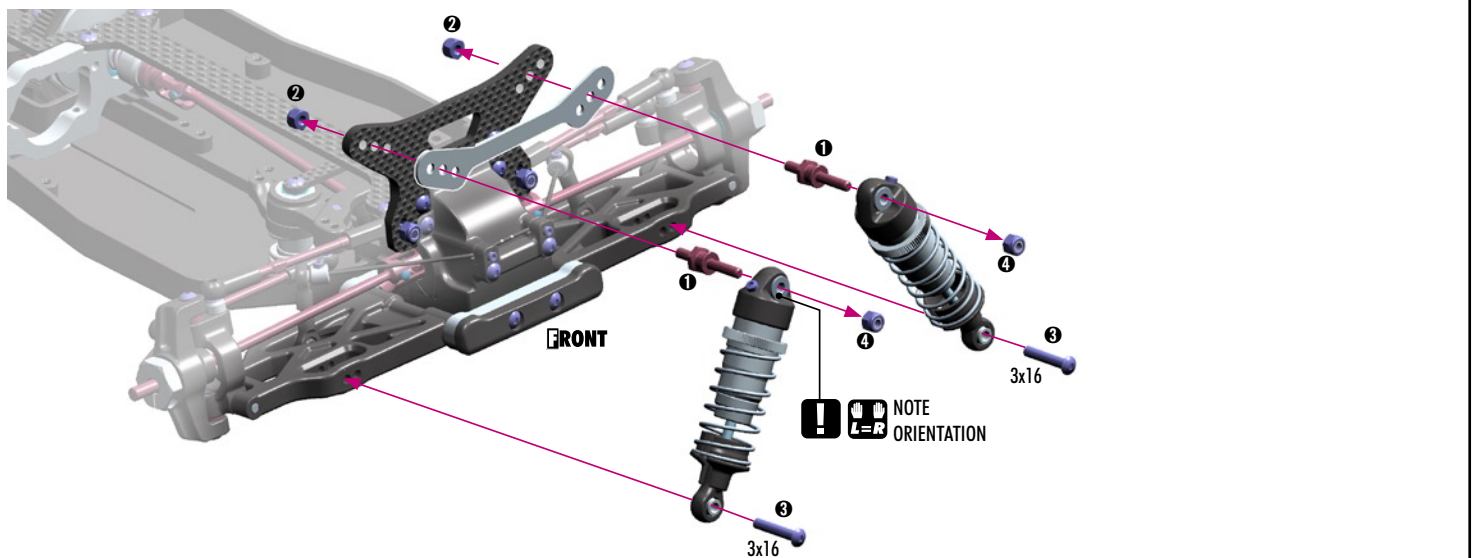
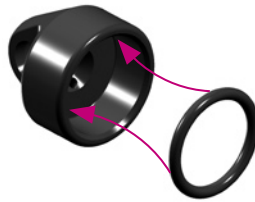

XRAY XB4 14

INSTRUCTION MANUAL SUPPLEMENTARY SHEET

Use this XB4 2014 Supplementary Instruction Sheet along with the standard XB4 Instruction Manual.

New and Improved Parts

All of these parts are new or updated from the previous versions.



#302665
Composite Ball Joint 4.9mm - Closed with Hole - V2 (4)

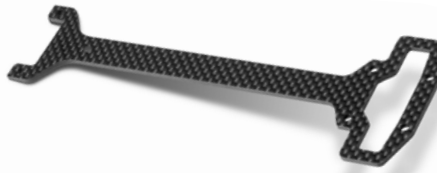

#361160
Graphite Front Upper Deck 2.0mm - V2



#361260
Composite Chassis Frame - V2

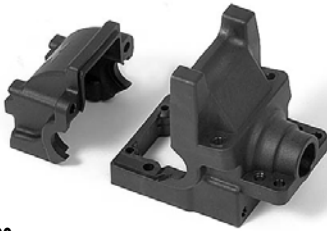

#362000
Diff Bulkhead Block Set Front - V2

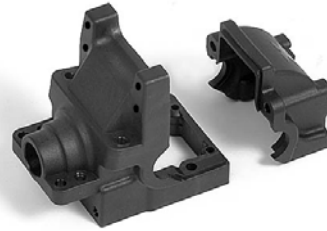

#362001
Diff Bulkhead Block Set Rear - V2



#362040
Front Shock Tower Protector



#362080
Graphite Shock Tower Front 3.0mm - V2



#363080
Graphite Shock Tower Rear 3.0mm - V2



#362111
Composite Suspension Arm Front Lower



#363111
Composite Suspension Arm Rear Lower Right



#363121
Composite Suspension Arm Rear Lower Left



#364120
Alu Slipper Clutch Plate - 7075 T6 Hardcoated - Lightweight

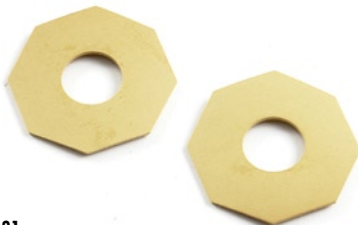

#364131
Slipper Clutch Pad SLS (2)



#364181
Slipper Clutch Spring C=50 - Black



#364935
Composite Differential Bevel Gear 35T - V2



#364960
Gear Diff Outdrive Adapter - HUDY Spring Steel™ - V2 (2)



#369910
Front Wheels Aerodisk - White - V2 (2)



#970120
O-Ring 12x1.0 (10)

! SHOCK TOWER PROTECTION

Please follow the instruction manual and seal the edges of the shock towers with CA to reinforce them and help prevent delamination.

Fine sandpaper

Use fine sandpaper to sand smooth the edges of all graphite parts.

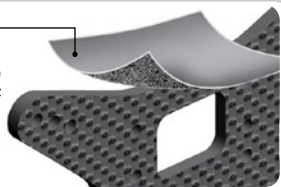

Apply CA glue to all edges of the graphite parts.

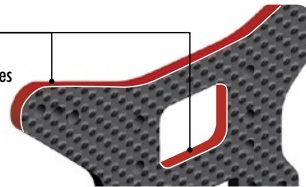

1. FRONT & REAR DIFFERENTIAL

PROPER AMOUNT OF OIL IN THE DIFFS

Please be very careful to properly fill your differentials as per the Instruction Manual. Use a digital scale to measure the exact amount of oil in the diff. Remember that during operation the diff gets hotter and the heat may allow the oil to expand. If there is too much oil inside it may interfere with the diff operation and damage the internal gears.

2. FRONT & REAR CENTRAL TRANSMISSION

DRIVE SHAFT COVER CAPS

Please follow the Instruction Manual and lubricate the drive shaft connecting joint properly so the drive shaft turns freely. In the event that not enough grease is used, the connecting pin may lock and may even, in extreme situations, push through the drive shaft cover cap.

GRAPHITE GREASE (HUDY #106210)

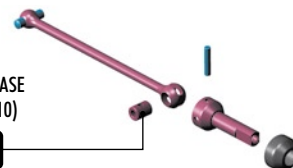

3. REAR SUSPENSION

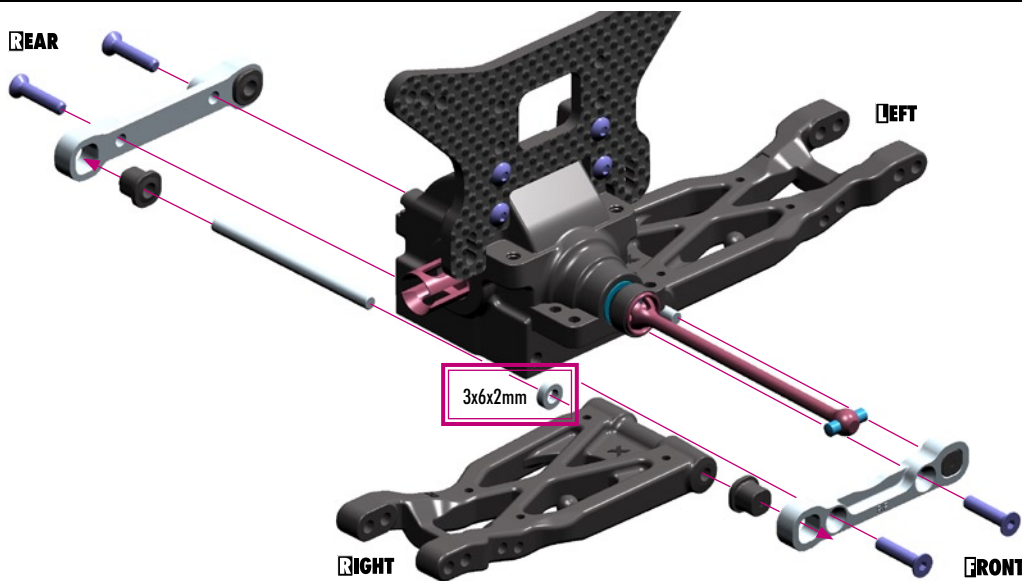

303123-K
SHIM 3x6x2

TIP OPTIONAL

For better stability and to make the car easier to drive in medium and high traction conditions, optional #362190 and #363190 graphite stiffeners may be used. Using only 4 screws, the graphite stiffener can be installed or removed which would completely change the characteristics of the car. Stiffeners may be used independently at front and/or rear.

IMPORTANT! Install / remove stiffeners equally on left & right sides.



2.5x6

REAR

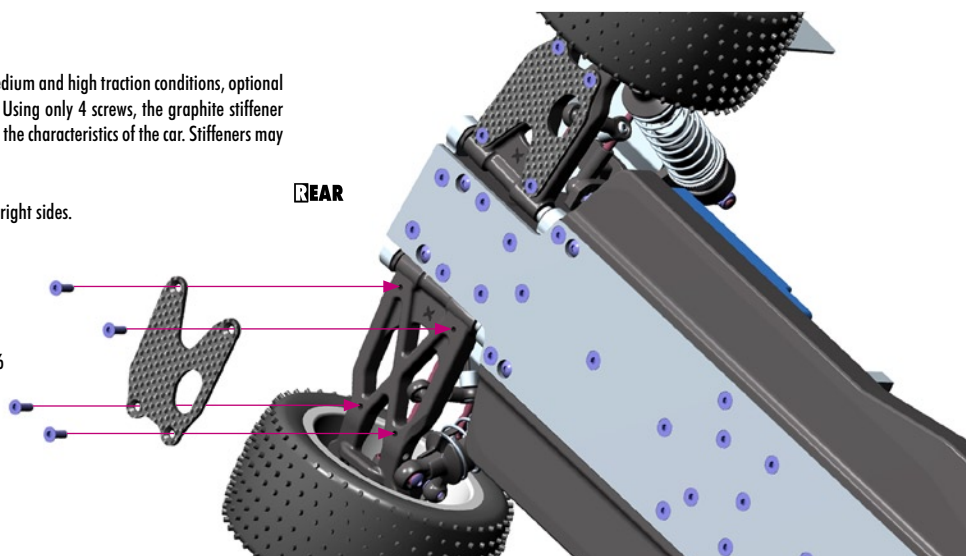

#363190
GRAPHITE REAR LOWER ARM PLATE 1.6MM (2) (OPTION)

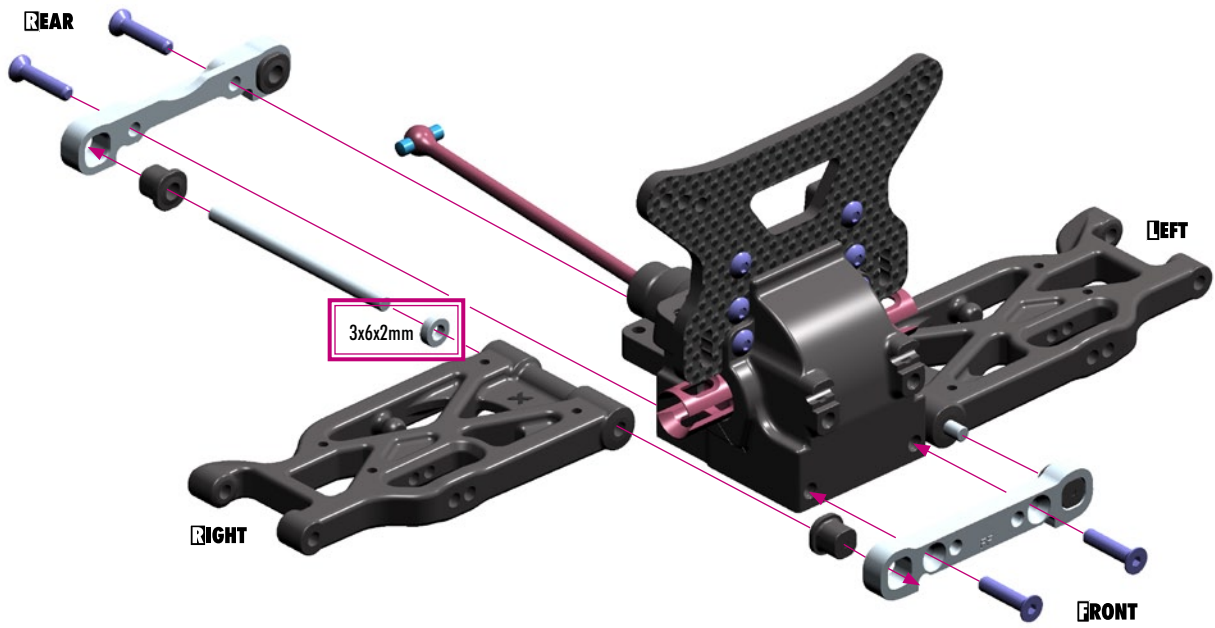

303123-K
SHIM 3x6x2

TIP OPTIONAL

For better stability and to make the car easier to drive in medium and high traction conditions, optional #362190 and #363190 graphite stiffeners may be used. Using only 4 screws, the graphite stiffener can be installed or removed which would completely change the characteristics of the car. Stiffeners may be used independently at front and/or rear.

IMPORTANT! Install / remove stiffeners equally on left & right sides.

2x L=R

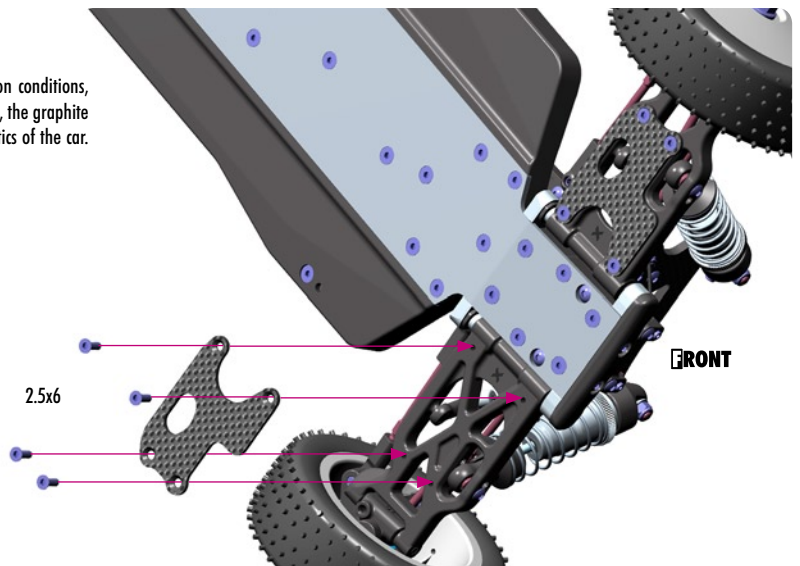

#362190
GRAPHITE FRONT LOWER ARM PLATE 1.6MM (2) (OPTION)

